

BẢNG KÊ NGUYÊN VẬT LIỆU

Số TT	Tên phụ kiện	Tải trọng phá hoại	Số lượng	Vật liệu chế tạo
1	Man ní	160	01	Hiện hữu
2	Mắt nối điều chỉnh	160	01	Hiện hữu
3	Mắt nối	160	01	Hiện hữu
4	Vòng treo đầu tròn	160	01	Hiện hữu
5	Arc/corona		01	Thép mạ kẽm - Thay mới
6	Cách điện U160BSP	160	15	Gốm/thủy tinh - Thay mới
7	Arc/corona		01	Thép mạ kẽm - Thay mới
8	Mắt nối	160	01	Hiện hữu
9	Khánh	160	01	Hiện hữu
10	Mắt nối	160	02	Hiện hữu
11	Mắt nối điều chỉnh	210	02	Hiện hữu
12	Khóa néo		02	Hiện hữu

Ghi chú:

- Tất cả các kích thước tính bằng đơn vị mm
- Tải trọng chuỗi cách điện là 160kN
- Số lượng bát: 15 bát loại U160BSP đang tính toán với dòng dò bát là 440mm/kV
- Chuỗi cách điện sử dụng cho dây dẫn 2xACSR 400/51

Dòng dò quy định (mm/kV)	Ký hiệu cách điện	Tổng chiều dài đường dò
25	NDD.1.160	6600

CÔNG TY TRUYỀN TẢI ĐIỆN ĐỘI TRUYỀN TẢI ĐIỆN NINH BÌNH			ĐƯỜNG DÂY 220KV THÁI BÌNH - TIỀN HẢI - TRỰC NINH		
Đội phó	Đỗ Đình Dũng		CHUỖI NÉO ĐƠN DÂY DẪN: NDD.1.160		
Kiểm tra	Lê Xuân Tú		BVTC	Bổ sung	10/2025
Người vẽ	Trần Hữu Tú				

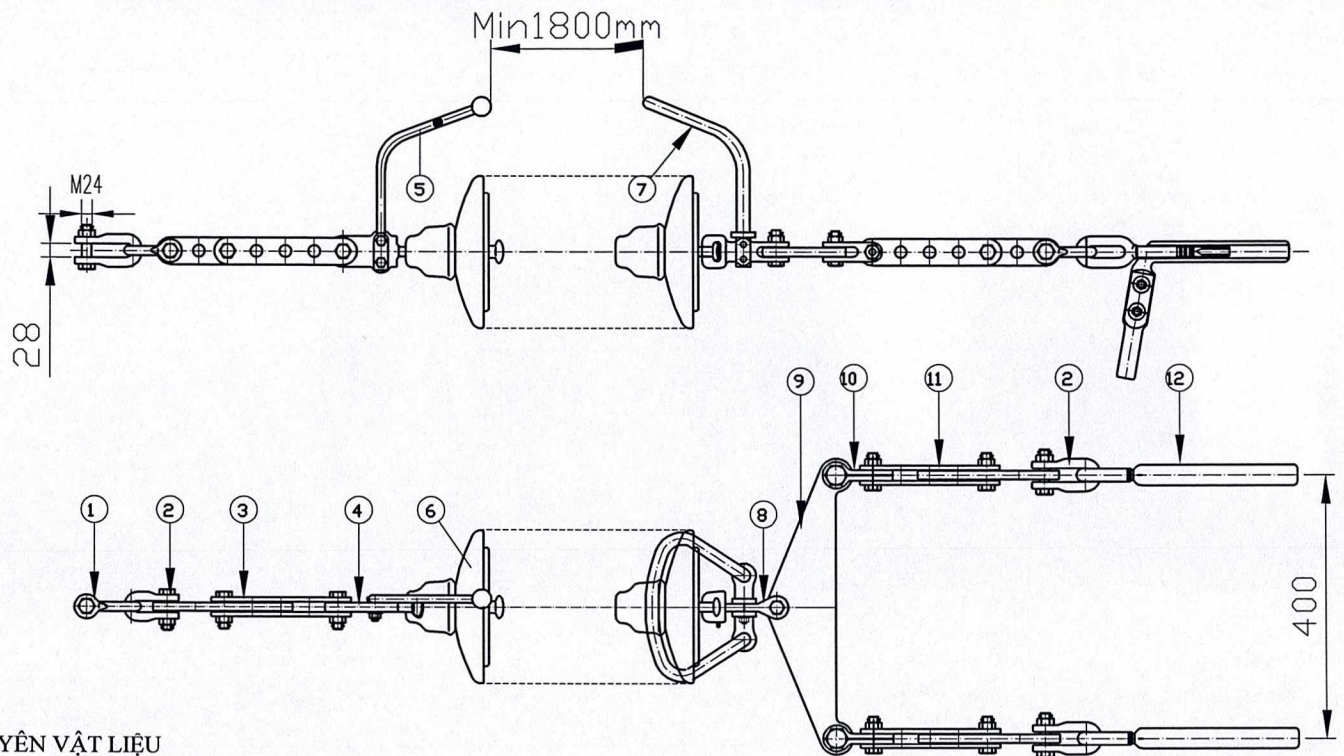

BẢNG KÊ NGUYÊN VẬT LIỆU

Số TT	Tên phụ kiện	Tải trọng phá hoại	Số lượng	Vật liệu chế tạo
1	Man ní	160	01	Hiện hữu
2	Mắt nối điều chỉnh	160	01	Hiện hữu
3	Mắt nối	160	01	Hiện hữu
4	Vòng treo đầu tròn	160	01	Hiện hữu
5	Arc/corona		01	Thép mạ kẽm - Thay mới
6	Cách điện U160BSP	160	15	Gôm/thủy tinh - Thay mới
7	Arc/corona		01	Thép mạ kẽm - Thay mới
8	Mắt nối	160	01	Hiện hữu
9	Khánh	160	01	Hiện hữu
10	Mắt nối	260	02	Hiện hữu
11	Mắt nối điều chỉnh	210	02	Hiện hữu
12	Khóa néo		02	Hiện hữu

Ghi chú:

- Tất cả các kích thước tính bằng đơn vị mm
- Tải trọng chuỗi cách điện là 160kN
- Số lượng bát: 15 bát loại U160BSP đang tính toán với dòng dò bát là 440mm/kV
- Chuỗi cách điện sử dụng cho dây dẫn 2xACSR 400/51

Dòng dò quy định (mm/kV)	Ký hiệu cách điện	Tổng chiều dài đường dò
25	NDD.1.160	6600

CÔNG TY TRUYỀN TẢI ĐIỆN 1 TRUYỀN TẢI ĐIỆN NINH BÌNH		ĐƯỜNG DÂY 220KV THÁI BÌNH - TIỀN HẢI - TRỰC NINH		
P.Giám đốc	Đỗ Đình Dũng	CHUỖI NÉO ĐƠN DÂY DẪN: NDD.1.160		
Kiểm tra	Lê Xuân Tú			
Người vẽ	Trần Hữu Tú	BVTC	Bổ sung	10/2025

THIS DRAWING IS THE PROPERTY OF "TAG CORPORATION" AND SHOULD NOT BE COPIED OR REPRODUCED WITHOUT PROPER AUTHORIZATION.

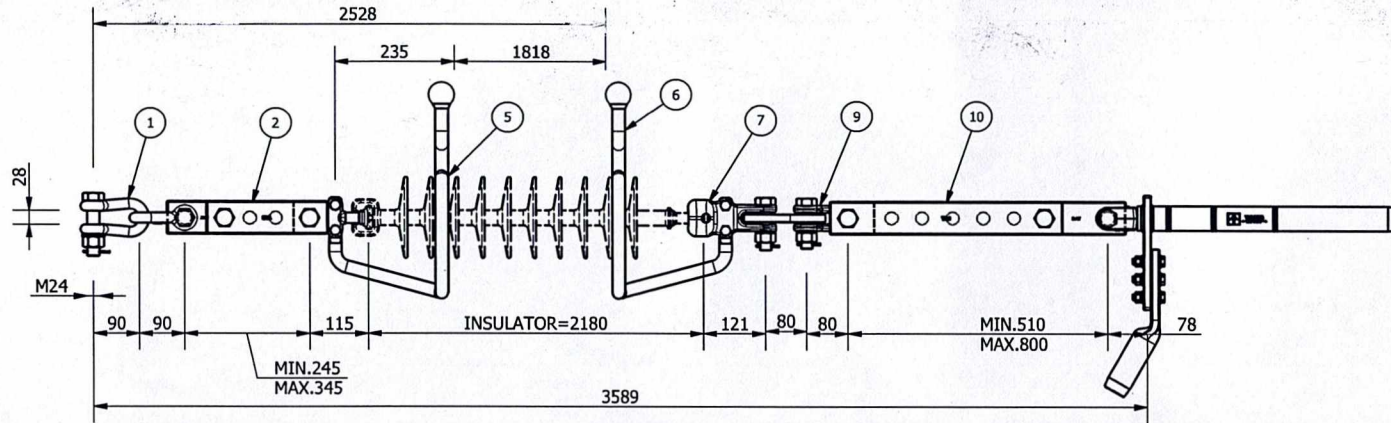

**FRONT VIEW**

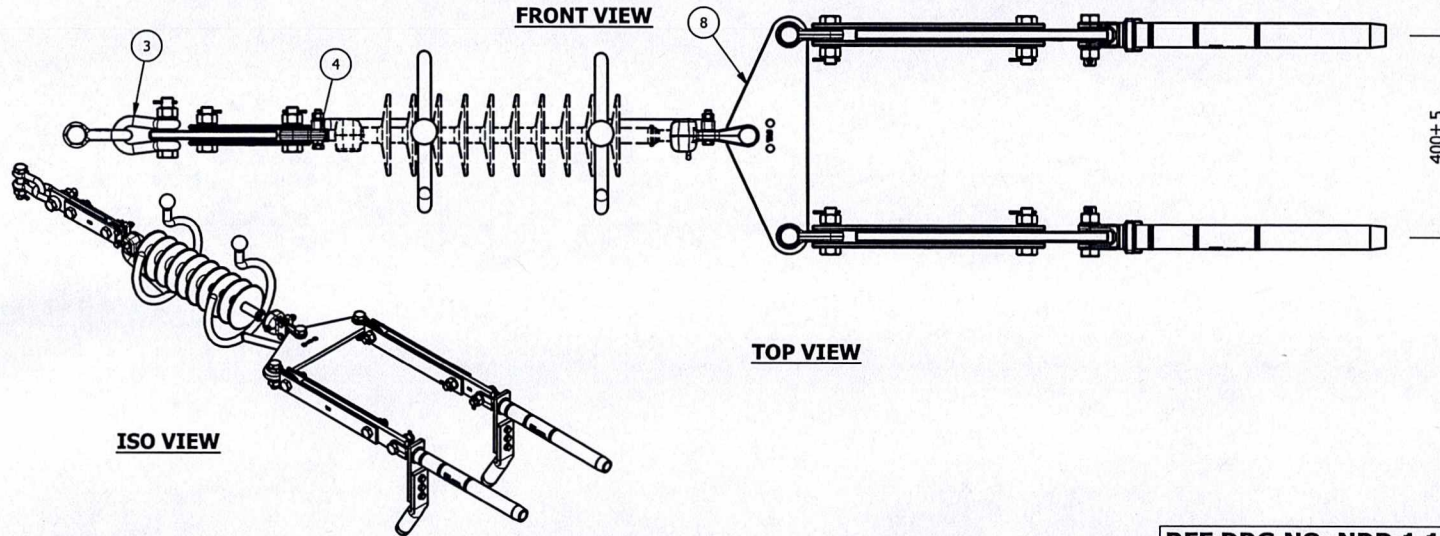

**TOP VIEW**

**ISO VIEW**

ITEM CODE	F	0	0	2	3	8	0	0	4
-----------	---	---	---	---	---	---	---	---	---

**TECHNICAL DATA**

1. ASSEMBLY MINIMUM ULTIMATE TENSILE STRENGTH - 160 KN.
2. BALL & SOCKET DESIGNATION - 20MM AS PER IEC - 120.
3. BALL & SOCKET LOCKING BY R-CLIP AS PER IEC-372. MADE OF S.S.
4. FERROUS PARTS-HOT DIP GALVANIZED AS PER ISO 1461.
5. GENERAL TOLERANCE UNLESS OTHERWISE SPECIFIED IS ±3%.
6. TOLERANCE ON LENGTH OF HARDWARE IS ±2%.
7. ALL DIMENSIONS ARE IN mm.
9. COMPOSITE INSULATOR NOT IN TAG'S SCOPE OF SUPPLY.
8. HARDWARE SUITABLE FOR ACSR/Mz 400/51 (Ø27.6) CONDUCTOR.
10. WEIGHT OF THE STRING - 59.42 kg (APPROX)
11. WEIGHT IS INDICATIVE ONLY.
12. SHORT CIRCUIT CURRENT CAPACITY - 41.1kA / 1 Sec (Maximum)

**PRODUCT CODE: ST/T2/LJ**

Project Name: Package 03: Supply and transport of insulators and fittings, OPGW cable and accessories for 220kV Thai Binh - Tien Hai - Truc Ninh double circuit transmission line

P.O.Ref.No.: -

Purchaser: M/s. NPMB

Contractor: M/s.

Manufacturer: TAG CORPORATION, CHENNAI.

REV	DATE	DESCRIPTION	APP. BY
3	24.01.2017	ITEM NO.5 & 6 (RTAH) CHANGED	
2	14.12.2016	ITEM CODE, PRODUCT CODE, COMP.CODE ADDED	
1	18.10.2016	(ITEM NO:5, 6) NEW ARCING HORNS ADDED	

**REVISION HISTORY**

ITEM NAME: 220KV SINGLE TENSION STRING FOR TWIN ACSR/Mz Ø27.6 CONDUCTOR

DRG.NO: TAG/E/ST/T2/LJ DATE: 08.08.2016

<p><b>TAG CORPORATION</b> CHROME PET, CHENNAI - 600 044 TAMILNADU, INDIA.</p>	DRAWN BY	B.A
	CKD. BY	R.M
	APP. BY	V.T.C
	SCALE: 1:10	

SL.NO	DESCRIPTION	MATERIAL	DRG. NO	COMP.CODE	ITEM CODE	UTS (KN)	QTY (NOS.)
11	DEAD END ASSEMBLY	AL.ALLOY / GALVANIZED STEEL	DEA3010	DEA3010	G00301021	-	2
10	ADJUSTABLE EXTENSION PLATE	GALVANIZED STEEL	AEP4202	AEP4202	G00202037	210	2
9	CLEVIS EYE	GALVANIZED STEEL	CE2000	CE2000	G00209015	160	2
8	TRIANGULAR YOKE PLATE	GALVANIZED STEEL	TYP4026	TYP4026	M00608145	160	1
7	H.H. SOCKET CLEVIS	GALVANIZED STEEL	HSC4000.2	HSC4000.2	G00223036	160	1
6	RING TYPE ARCING HORN	GALVANIZED STEEL	RTAH4207	RTAH4207	M00609127	-	1
5	RING TYPE ARCING HORN	GALVANIZED STEEL	RTAH4206	RTAH4206	M00609126	-	1
4	BALL EYE	GALVANIZED STEEL	BE4001	BE4001	G00206003	160	1
3	D-SHACKLE	GALVANIZED STEEL	DS4008	DS4008	G00211049	160	1
2	ADJUSTABLE EXTENSION PLATE	GALVANIZED STEEL	AEP3014	AEP3014	G00202041	160	1
1	D-SHACKLE	GALVANIZED STEEL	DS4015	DS4015	G00211053	160	1

**REF.DRG.NO: NDD.1.160**

SL.NO	DESCRIPTION	MATERIAL	DRG. NO	COMP.CODE	ITEM CODE	UTS (KN)	QTY (NOS.)
<b>BILL OF MATERIAL</b>							

THIS DRAWING IS THE PROPERTY OF "TAG CORPORATION" AND SHOULD NOT BE COPIED OR REPRODUCED WITHOUT PROPER AUTHORIZATION.

ITEM CODE G 0 0 2 1 1 0 5 3

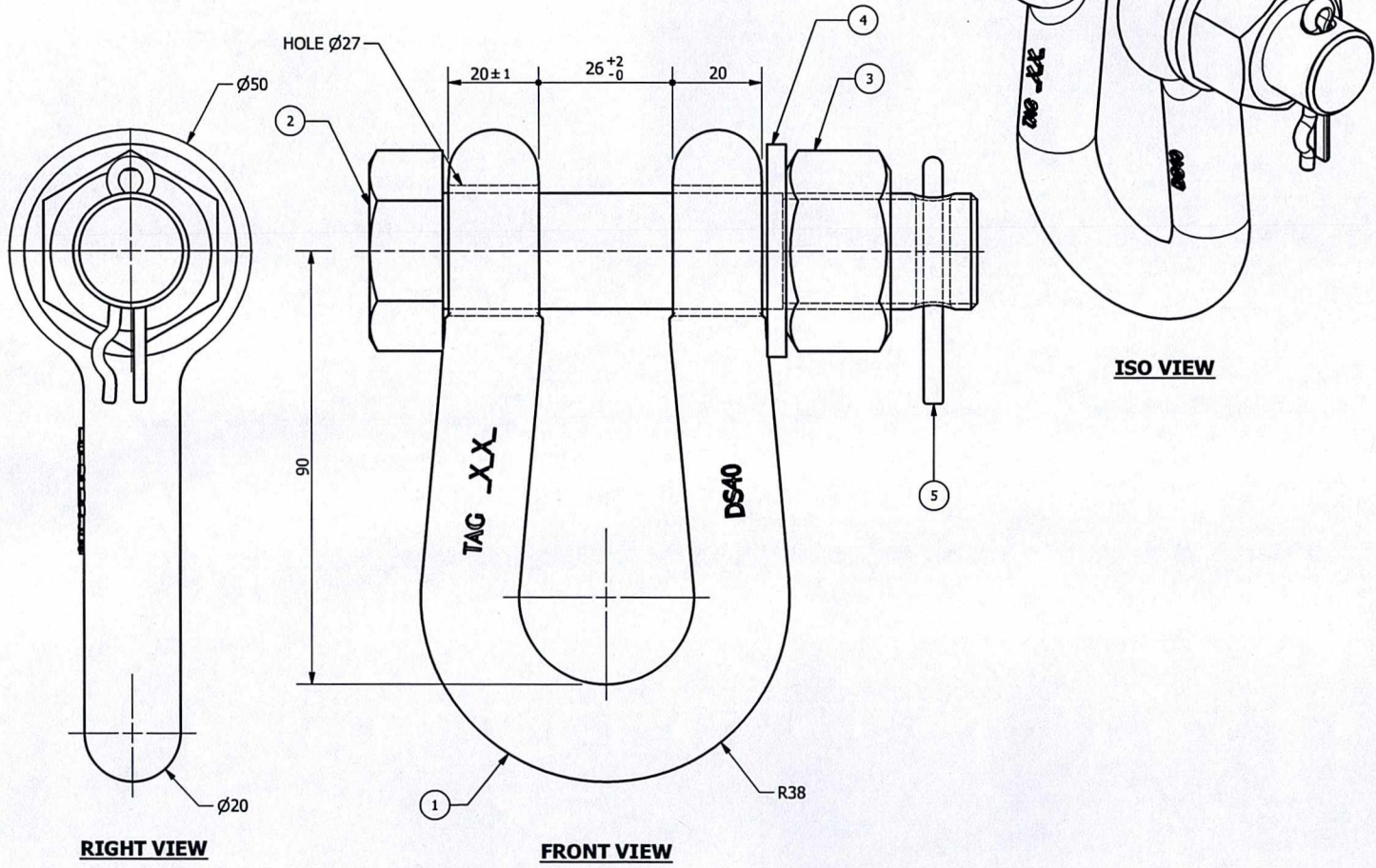

- TECHNICAL DATA**
- HOT DIP GALVANIZED AS PER ISO : 1461.
  - BREAKING STRENGTH - **160 KN**
  - GENERAL TOLERANCE UNLESS OTHERWISE SPECIFIED IS  $\pm 3\%$ .
  - TOTAL WEIGHT - **1.47 kg.**
  - WEIGHT IS INDICATIVE ONLY.
  - ALL DIMENSIONS ARE IN MM.

Project Name	Package 03: Supply and transport of insulators and fittings, OPGW cable and accessories for 220kV Thai Binh - Tien Hai - Truc Ninh double circuit transmission line
P.O.Ref.No.	-
Purchaser	M/s. NPMB
Contractor	M/s.
Manufacturer	TAG CORPORATION, CHENNAI.

REV	DATE	DESCRIPTION	APP. BY
REVISION HISTORY			

ITEM NAME: **D-SHACKLE**

DRG.NO: <b>DS4015</b>	DATE	14.12.2016
<b>TAG CORPORATION</b> CHROMEPET, CHENNAI - 600 044 EXPORT TAMILNADU, INDIA.	DRAWN BY	P.R.B
	CKD. BY	R.M
	APP. BY	V.T.C
SCALE: 1 : 1		

ITEM	DESCRIPTION	MATERIAL	ITEM CODE	UTS	QTY (NOS.)
5	SPLIT PIN(SP/002)	S.S (AISI - 304)	B00210002	-	1
4	FLAT WASHER (M24)	GALVANIZED STEEL	B00205007	-	1
3	NUT (M24)	GALVANIZED STEEL (P.C.5.0)	-	-	1
2	BOLT (M24X110)	GALVANIZED STEEL (P.C.5.6)	B00202048	-	1
1	D-SHACKLE	GALVANIZED STEEL	M00504047	160	1

**BILL OF MATERIAL**

THIS DRAWING IS THE PROPERTY OF "TAG CORPORATION" AND SHOULD NOT BE COPIED OR REPRODUCED WITHOUT PROPER AUTHORIZATION.

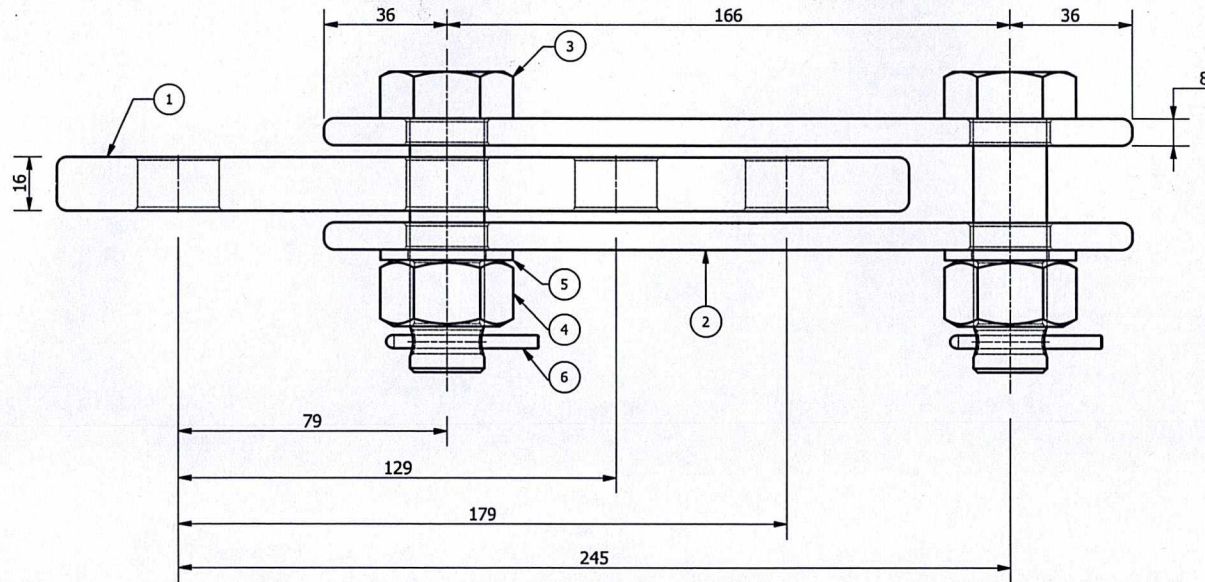

**FRONT VIEW**

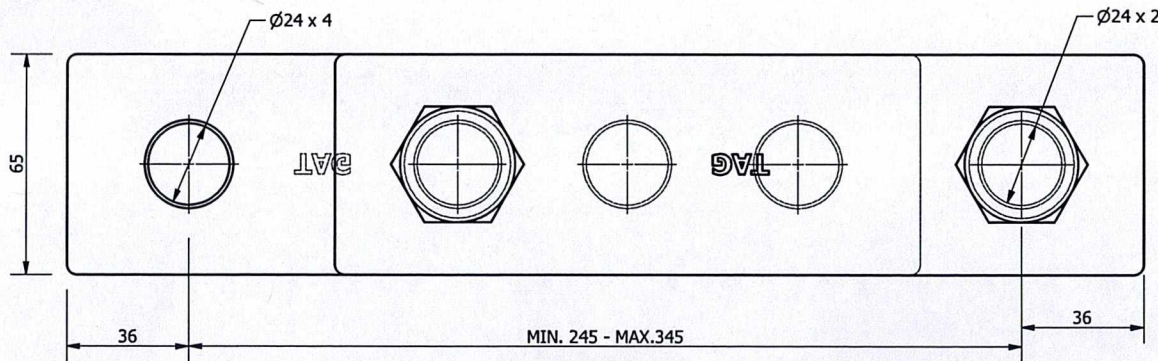

**TOP VIEW**

ITEM CODE	G	0	0	2	0	2	0	4	1
-----------	---	---	---	---	---	---	---	---	---

**TECHNICAL DATA**

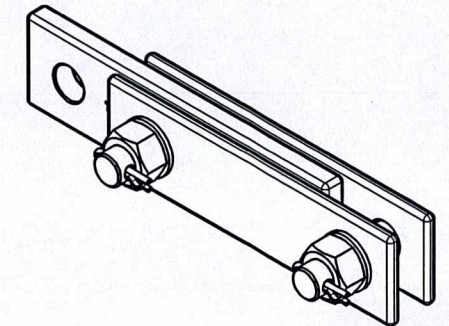

- HOT DIP GALVANIZED AS PER ISO : 1461.
- BREAKING STRENGTH - **160 KN.**
- GENERAL TOLERANCE UNLESS OTHERWISE SPECIFIED IS  $\pm 3\%$ .
- TOTAL WEIGHT - **4.50 kg.**
- WEIGHT IS INDICATIVE ONLY.
- ALL DIMENSIONS ARE IN MM.



**ISO VIEW**

Project Name	Package 03: Supply and transport of insulators and fittings, OPGW cable and accessories for 220kV Thai Binh - Tien Hai - Truc Ninh double circuit transmission line
P.O.Ref.No.	-
Purchaser	M/s. NPMB
Contractor	M/s.
Manufacturer	TAG CORPORATION, CHENNAI.

REV	DATE	DESCRIPTION	APP. BY
REVISION HISTORY			

ITEM NAME: <b>ADJUSTABLE EXTENSION PLATE</b>		
DRG.NO: <b>AEP3014</b>	DATE 14.12.2016	DRAWN BY P.R.B
 <b>TAG CORPORATION</b> CHROME PET, CHENNAI - 600 044 EXPORT TAMILNADU, INDIA.	CKD. BY R.M	APP. BY V.T.C
	SCALE: 1:1.5 	

ITEM	DESCRIPTION	MATERIAL	ITEM CODE	UTS	QTY (NOS.)
6	SPLIT PIN (SP/001)	S.S (AISI - 304)	B00210001	-	2
5	FLAT WASHER (M22)	GALVANIZED STEEL	B00205006	-	2
4	NUT (M22)	GALVANIZED STEEL (P.C.5.0)	-	-	2
3	BOLT (M22X75)	GALVANIZED STEEL (P.C.5.6)	B00202071	-	2
2	ADJUSTABLE EXTENSION PLATE	GALVANIZED STEEL	M00603091	80	2
1	ADJUSTABLE EXTENSION PLATE	GALVANIZED STEEL	M00601074	160	1

**BILL OF MATERIAL**

THIS DRAWING IS THE PROPERTY OF "TAG CORPORATION" AND SHOULD NOT BE COPIED OR REPRODUCED WITHOUT PROPER AUTHORIZATION.

ITEM CODE G 0 0 2 1 1 0 4 9

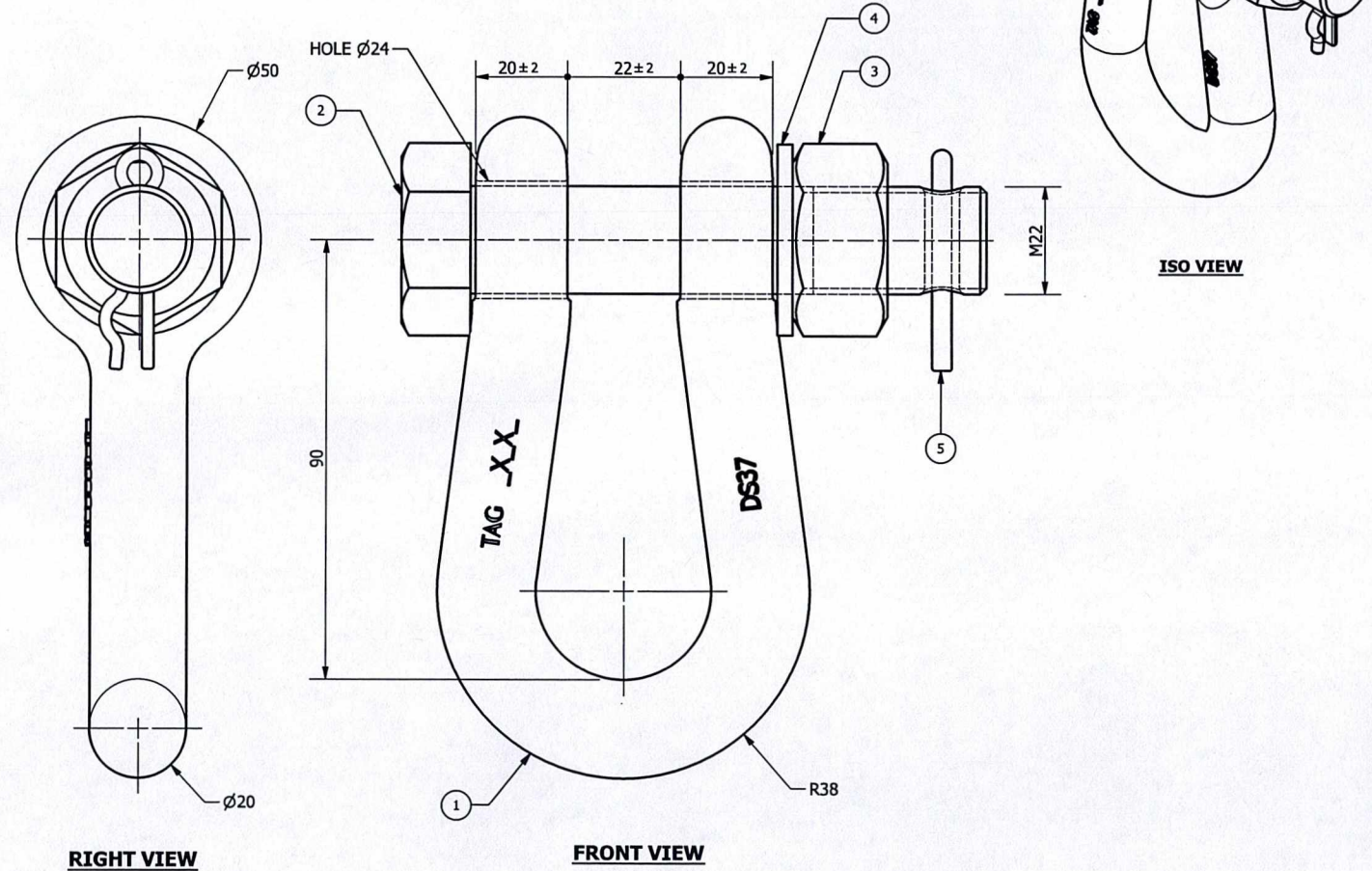

**TECHNICAL DATA**

1. HOT DIP GALVANIZED AS PER ISO : 1461.
2. BREAKING STRENGTH - **160 KN**
3. GENERAL TOLERANCE UNLESS OTHERWISE SPECIFIED IS  $\pm 3\%$ .
4. WEIGHT IS INDICATIVE ONLY.
5. TOTAL WEIGHT - **1.36 kg.**
6. ALL DIMENSIONS ARE IN MM.

Project Name	Package 03: Supply and transport of insulators and fittings, OPGW cable and accessories for 220kV Thai Binh - Tien Hai - Truc Ninh double circuit transmission line
P.O.Ref.No.	-
Purchaser	M/s. NPMB
Contractor	M/s.
Manufacturer	TAG CORPORATION, CHENNAI.

REV	DATE	DESCRIPTION	APP. BY
REVISION HISTORY			

ITEM NAME:		<b>D-SHACKLE</b>	
DRG.NO: <b>DS4008</b>	DATE	14.12.2016	
	DRAWN BY	P.R.B	
	CKD. BY	R.M	
	APP. BY	V.T.C	
TAG CORPORATION CHROME PET, CHENNAI - 600 044 EXPORT TAMILNADU, INDIA.		SCALE: 1 : 1	

ITEM	DESCRIPTION	MATERIAL	ITEM CODE	UTS	QTY (NOS.)
5	SPLIT PIN(SP/001)	S.S (AISI - 304)	B00210001	-	1
4	FLAT WASHER (M22)	GALVANIZED STEEL	B00205006	-	1
3	NUT (M22)	GALVANIZED STEEL (P.C.5.0)	-	-	1
2	BOLT (M22X105)	GALVANIZED STEEL (P.C.5.6)	B00202045	-	1
1	D-SHACKLE	GALVANIZED STEEL	M00504043	160	1

**BILL OF MATERIAL**

THIS DRAWING IS THE PROPERTY OF "TAG CORPORATION" AND SHOULD NOT BE COPIED OR REPRODUCED WITHOUT PROPER AUTHORIZATION.

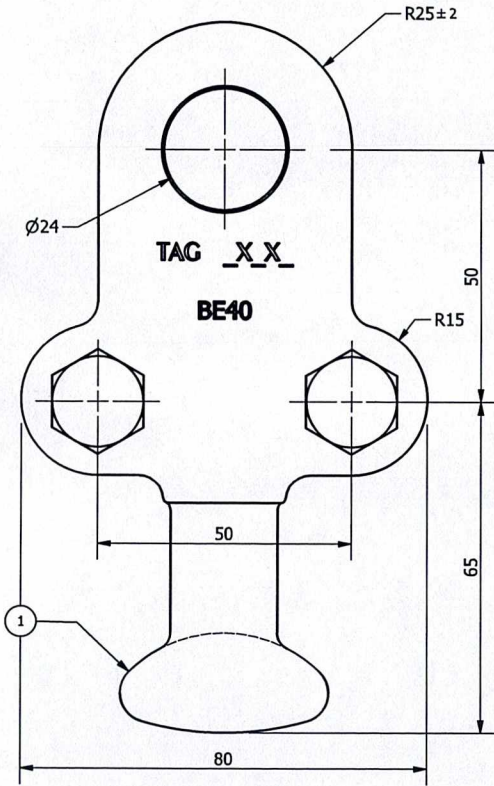

**FRONT VIEW**

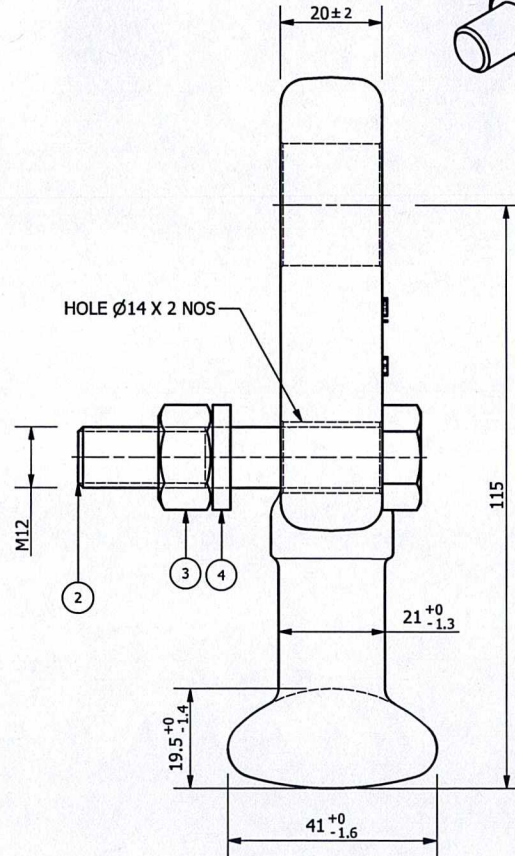

**LEFT VIEW**

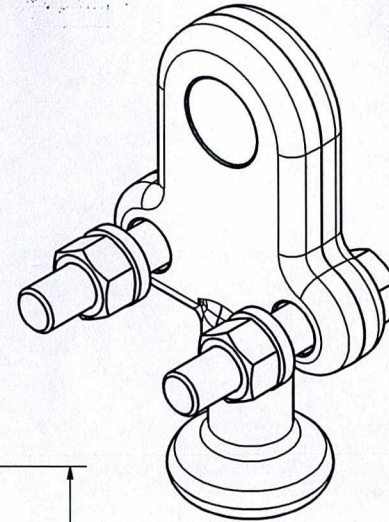

**ISO VIEW**

ITEM CODE G 0 0 2 0 6 0 0 3

**TECHNICAL DATA**

1. HOT DIP GALVANIZED AS PER ISO : 1461
2. BREAKING STRENGTH - **160 KN.**
3. BALL DESIGNATION **20 mm** AS PER IEC-120.
4. GENERAL TOLERANCE UNLESS OTHERWISE SPECIFIED IS ±3%.
5. TOTAL WEIGHT - **1.04 kg.**
6. WEIGHT IS INDICATIVE ONLY.
7. ALL DIMENSIONS ARE IN MM.

Project Name Package 03: Supply and transport of insulators and fittings, OPGW cable and accessories for 220kV Thai Binh - Tien Hai - Truc Ninh double circuit transmission line

P.O.Ref.No. -

Purchaser M/s. NPMB

Contractor M/s.

Manufacturer TAG CORPORATION, CHENNAI.

REV	DATE	DESCRIPTION	APP. BY
REVISION HISTORY			

ITEM NAME:

**BALL EYE**

DRG.NO: <b>BE4001</b>	DATE	14.12.2016
 <b>TAG CORPORATION</b> CHROME PET, CHENNAI - 600 044 EXPORT TAMILNADU, INDIA.	DRAWN BY	P.R.B
	CKD. BY	R.M
	APP. BY	V.T.C
SCALE: 1 : 1		

ITEM	DESCRIPTION	MATERIAL	ITEM CODE	UTS	QTY (NOS.)
4	SPRING WASHER (M12)	SPRING STEEL	B00211002	-	2
3	NUT (M12)	GALVANIZED STEEL (P.C.5.0)	-	-	2
2	BOLT (M12X60)	GALVANIZED STEEL (P.C.5.6)	B00202012	-	2
1	BALL EYE	GALVANIZED STEEL	M00502003	160	1

**BILL OF MATERIAL**

THIS DRAWING IS THE PROPERTY OF "TAG CORPORATION" AND SHOULD NOT BE COPIED OR REPRODUCED WITHOUT PROPER AUTHORIZATION.

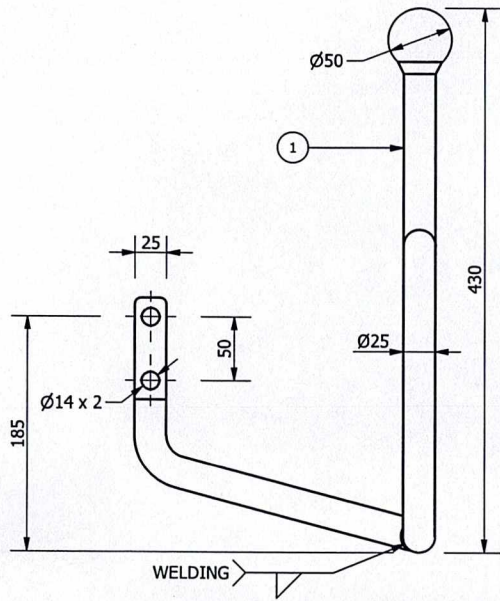

**FRONT VIEW**

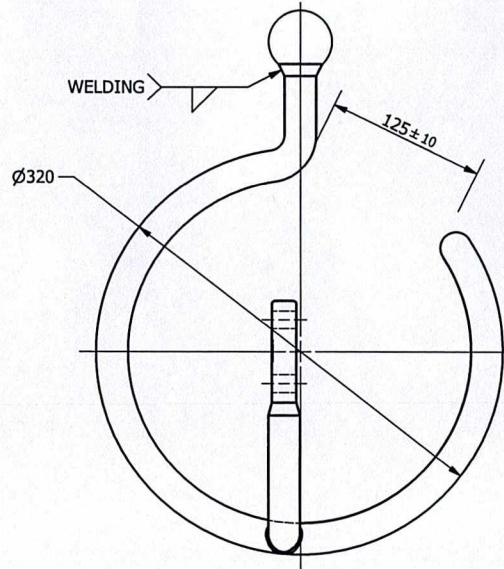

**LEFT VIEW**

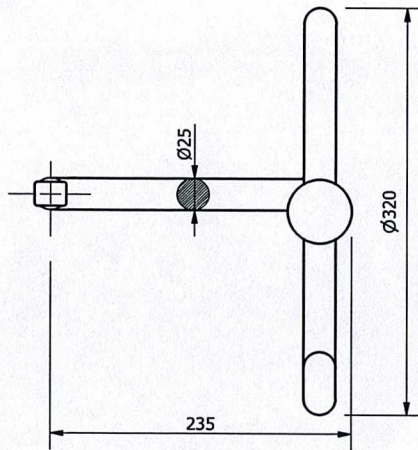

**TOP VIEW**

ITEM CODE M 0 0 6 0 9 1 2 6

**TECHNICAL DATA**

1. HOT DIP GALVANIZED AS PER ISO : 1461
2. GENERAL TOLERANCE UNLESS OTHERWISE SPECIFIED IS ±3%.
3. WELDING BY ELECTRIC ARC WELDING.
4. TOTAL WEIGHT - **5.07 kg.**
5. WEIGHT IS INDICATIVE ONLY.
6. ALL DIMENSIONS ARE IN MM.

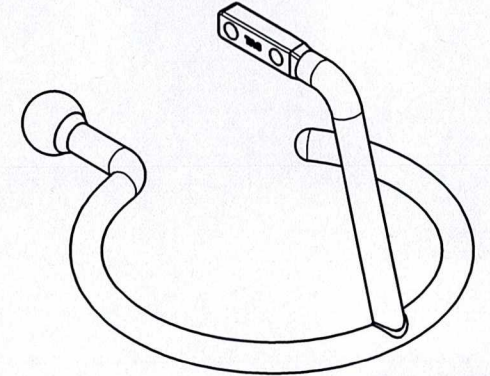

**ISO VIEW**

Project Name	Package 03: Supply and transport of insulators and fittings, OPGW cable and accessories for 220kV Thai Binh - Tien Hai - Truc Ninh double circuit transmission line		
P.O.Ref.No.	-		
Purchaser	M/s. NPMB		
Contractor	M/s.		
Manufacturer	TAG CORPORATION, CHENNAI.		
REV	DATE	DESCRIPTION	APP. BY
REVISION HISTORY			

ITEM NAME: **RING TYPE ARCING HORN**

DRG.NO: <b>RTAH4206</b>	DATE	01.12.2016
	DRAWN BY	P.P
	CKD. BY	R.M
	APP. BY	V.T.C
EXPORT TAMILNADU, INDIA.	SCALE: 1 : 4	

SL.NO	DESCRIPTION	MATERIAL	ITEM CODE	UTS (KN)	QTY (NOS.)
1	RING TYPE ARCING HORN	GALVANIZED STEEL	M00609126	-	1

**BILL OF MATERIAL**

THIS DRAWING IS THE PROPERTY OF "TAG CORPORATION" AND SHOULD NOT BE COPIED OR REPRODUCED WITHOUT PROPER AUTHORIZATION.

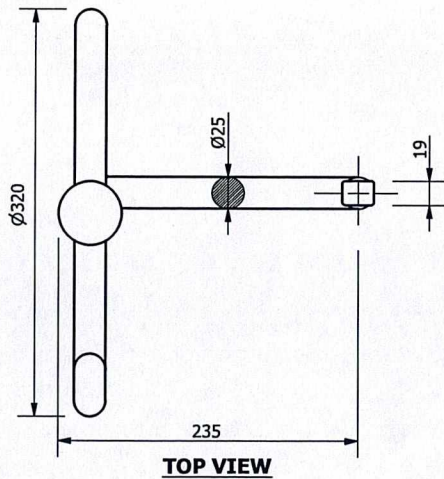
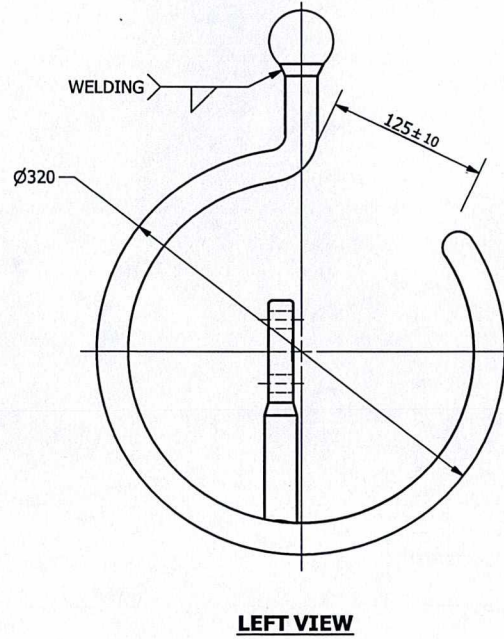
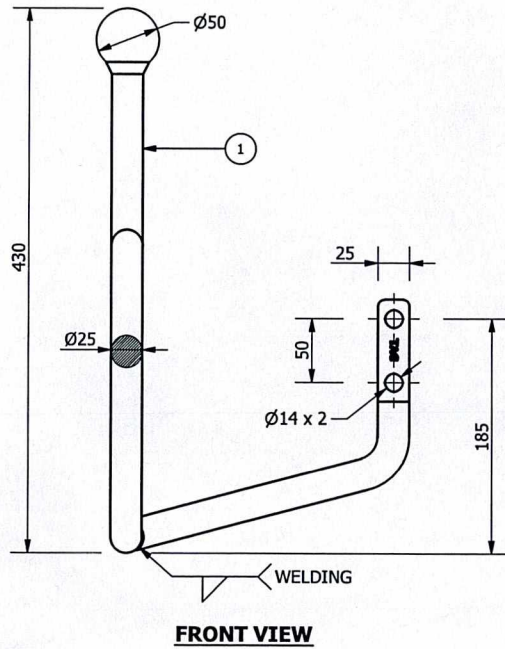

ITEM CODE	M	0	0	6	0	9	1	2	7
-----------	---	---	---	---	---	---	---	---	---

**TECHNICAL DATA**

- HOT DIP GALVANIZED AS PER ISO : 1461
- GENERAL TOLERANCE UNLESS OTHERWISE SPECIFIED IS  $\pm 3\%$ .
- WELDING BY ELECTRIC ARC WELDING.
- TOTAL WEIGHT - **5.07 kg.**
- ALL DIMENSIONS ARE IN MM.
- NO DEFORMATION LOAD IS 1 KN.

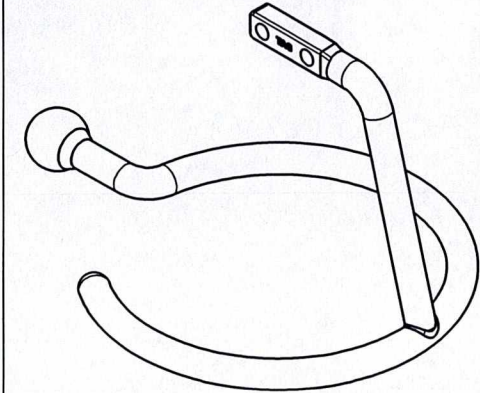

**ISO VIEW**

Project Name	Package 03: Supply and transport of insulators and fittings, OPGW cable and accessories for 220kV Thai Binh - Tien Hai - Truc Ninh double circuit transmission line
P.O.Ref.No.	-
Purchaser	M/s. NPMB
Contractor	M/s.
Manufacturer	TAG CORPORATION, CHENNAI.

REV	DATE	DESCRIPTION	APP. BY
REVISION HISTORY			

ITEM NAME:  
**RING TYPE ARCING HORN**

DRG.NO: <b>RTAH4207</b>	DATE: 01.12.2016
	DRAWN BY: P.P
	CKD. BY: R.M
	APP. BY: V.T.C
SCALE: 1 : 4	

SL.NO	DESCRIPTION	MATERIAL	ITEM CODE	UTS (KN)	QTY (NOS.)
1	RING TYPE ARCING HORN	GALVANIZED STEEL	M00609127	-	1

**BILL OF MATERIAL**

**TAG CORPORATION**  
CHROMEPET, CHENNAI - 600 044  
TAMILNADU, INDIA.

THIS DRAWING IS THE PROPERTY OF "TAG CORPORATION" AND SHOULD NOT BE COPIED OR REPRODUCED WITHOUT PROPER AUTHORIZATION.

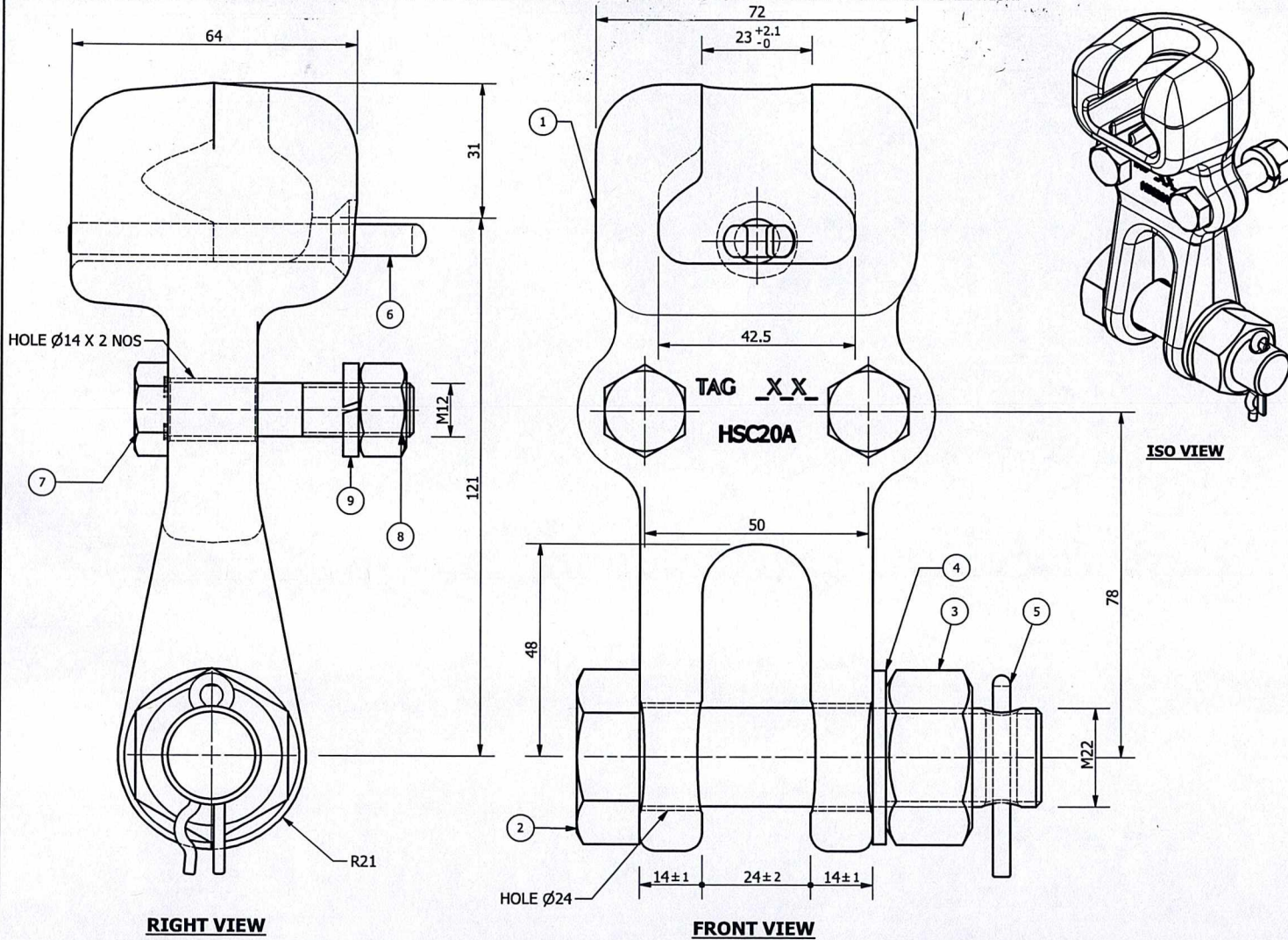

ITEM CODE | G | 0 | 0 | 2 | 2 | 3 | 0 | 3 | 6

- TECHNICAL DATA**
- HOT DIP GALVANIZED AS PER ISO : 1461.
  - BREAKING STRENGTH - **160 KN**
  - SOCKET DESIGNATION **20 mm** AS PER IEC-120.
  - GENERAL TOLERANCE UNLESS OTHERWISE SPECIFIED IS  $\pm 3\%$ .
  - TOTAL WEIGHT - **2.50 kg.**
  - WEIGHT IS INDICATIVE ONLY.
  - ALL DIMENSIONS ARE IN MM.

Project Name	Package 03: Supply and transport of insulators and fittings, OPGW cable and accessories for 220kV Thai Binh - Tien Hai - Truc Ninh double circuit transmission line
P.O.Ref.No.	-
Purchaser	M/s. NPMB
Contractor	M/s.
Manufacturer	TAG CORPORATION, CHENNAI.

REV	DATE	DESCRIPTION	APP. BY
REVISION HISTORY			

ITEM NAME: **H.H. SOCKET CLEVIS**

DRG.NO: <b>HSC4000.2</b>	DATE: 14.12.2016
	DRAWN BY: P.R.B
	CKD. BY: R.M
	APP. BY: V.T.C
SCALE: 1:1	

ITEM	DESCRIPTION	MATERIAL	ITEM CODE	UTS	QTY (NOS.)
9	SPRING WASHER (M12)	SPRING STEEL	B00211002	-	2
8	NUT (M12)	GALVANIZED STEEL (P.C.5.0)	-	-	2
7	BOLT (M12X55)	GALVANIZED STEEL (P.C.5.6)	B00202011	-	2
6	R-CLIP (R/C002)	S.S (AISI - 304)	B00208002	-	1
5	SPLIT PIN(SP/001)	S.S (AISI - 304)	B00210001	-	1
4	FLAT WASHER (M22)	GALVANIZED STEEL	B00205006	-	1
3	NUT (M22)	GALVANIZED STEEL (P.C.5.0)	-	-	1
2	BOLT (M22X90)	GALVANIZED STEEL (P.C.5.6)	B00202064	-	1
1	H.H. SOCKET CLEVIS	GALVANIZED STEEL	M00507020	160	1

**BILL OF MATERIAL**

**TAG CORPORATION**  
 CHROME PET, CHENNAI - 600 044  
 EXPORT TAMILNADU, INDIA.

THIS DRAWING IS THE PROPERTY OF "TAG CORPORATION" AND SHOULD NOT BE COPIED OR REPRODUCED WITHOUT PROPER AUTHORIZATION.

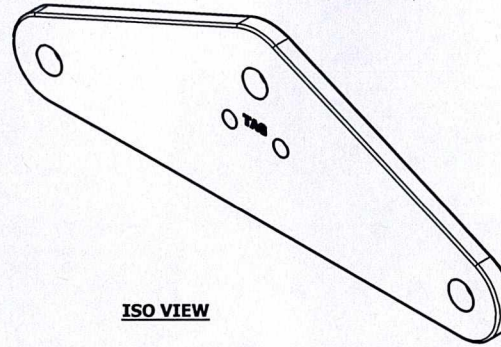

ISO VIEW

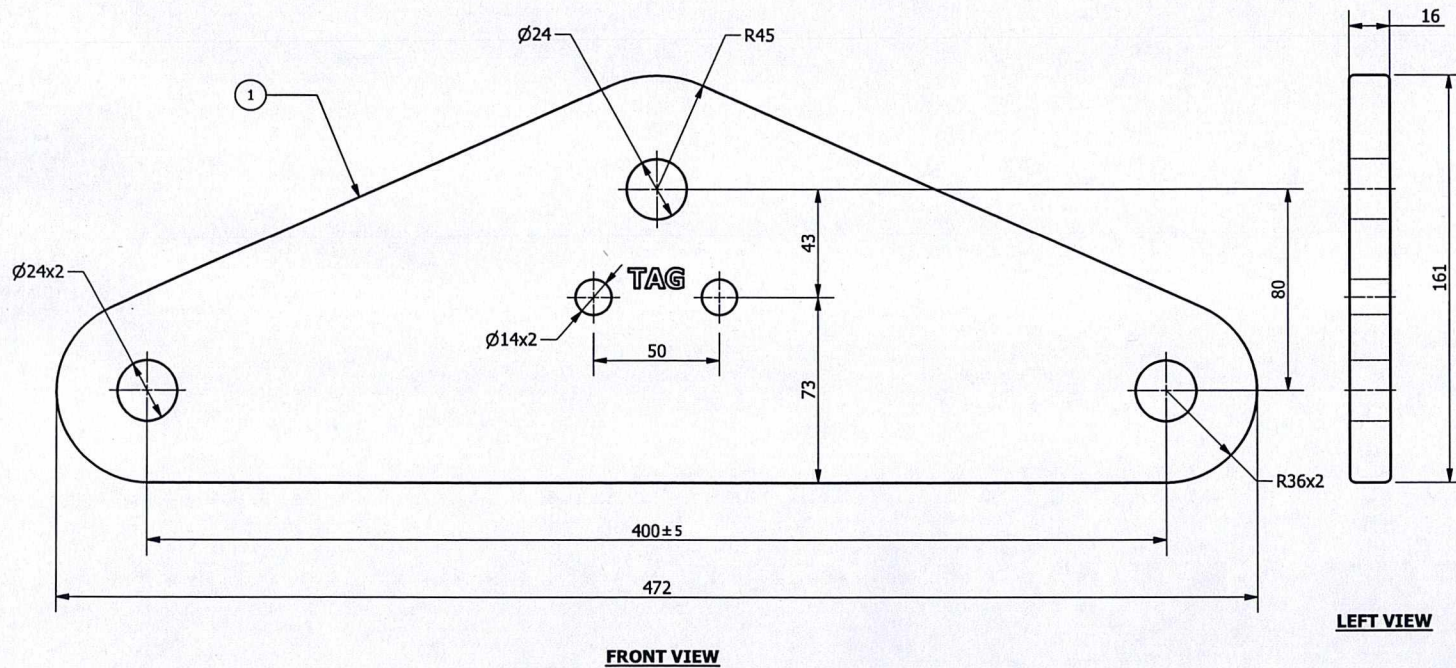

FRONT VIEW

LEFT VIEW

ITEM CODE	M	0	0	6	0	8	1	4	5
-----------	---	---	---	---	---	---	---	---	---

**TECHNICAL DATA**

1. HOT DIP GALVANIZED AS PER ISO : 1461.
2. BREAKING STRENGTH - **160 KN.**
3. GENERAL TOLERANCE UNLESS OTHERWISE SPECIFIED IS  $\pm 3\%$ .
4. TOTAL WEIGHT - **6.33 kg.**
5. WEIGHT IS INDICATIVE ONLY.
6. ALL DIMENSIONS ARE IN MM.

Project Name: Package 03: Supply and transport of insulators and fittings, OPGW cable and accessories for 220kV Thai Binh - Tien Hai - Truc Ninh double circuit transmission line

P.O.Ref.No.: -

Purchaser: M/s. NPMB

Contractor: M/s.

Manufacturer: TAG CORPORATION, CHENNAI.

REV	DATE	DESCRIPTION	APP. BY
REVISION HISTORY			

ITEM NAME: **TRIANGULAR YOKE PLATE**

DRG.NO: **TYP4026**      DATE: 14.12.2016

<p><b>TAG CORPORATION</b> CHROMEPET, CHENNAI - 600 044 EXPORT TAMILNADU, INDIA.</p>	DRAWN BY: P.R.B	14.12.2016
	CKD. BY: R.M	
	APP. BY: V.T.C	
SCALE: 1:2		

ITEM	DESCRIPTION	MATERIAL	ITEM CODE	UTS (KN)	QTY (NOS.)
1	TRIANGULAR YOKE PLATE	GALVANIZED STEEL	M00608145	160	1
<b>BILL OF MATERIAL</b>					

THIS DRAWING IS THE PROPERTY OF "TAG CORPORATION" AND SHOULD NOT BE COPIED OR REPRODUCED WITHOUT PROPER AUTHORIZATION.

ITEM CODE G 0 0 2 0 9 0 1 5

**TECHNICAL DATA**  
 1. HOT DIP GALVANIZED AS PER ISO : 1461.  
 2. BREAKING STRENGTH - **160 KN**  
 3. GENERAL TOLERANCE UNLESS OTHERWISE SPECIFIED IS ±3%.  
 4. TOTAL WEIGHT - **1.17 kg.**  
 5. WEIGHT IS INDICATIVE ONLY.  
 6. ALL DIMENSIONS ARE IN MM.

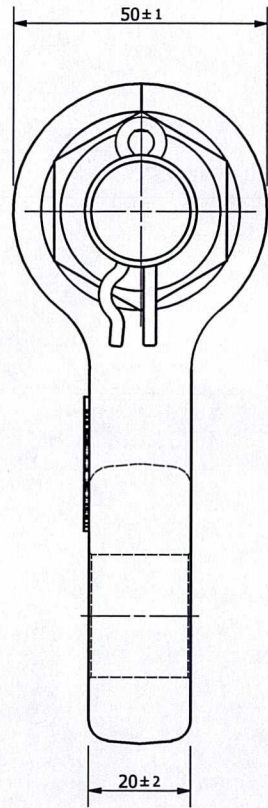

**RIGHT VIEW**

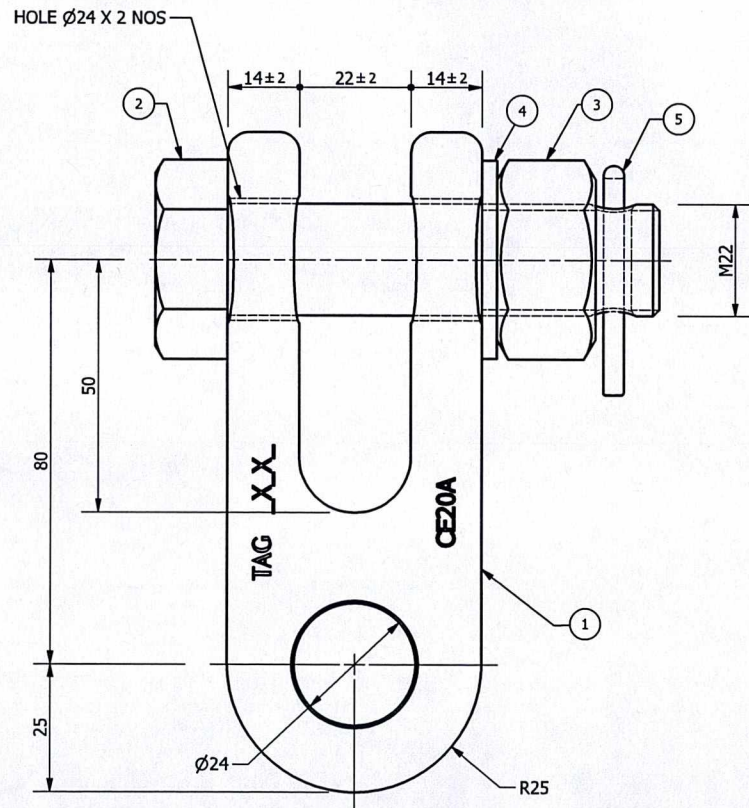

**FRONT VIEW**

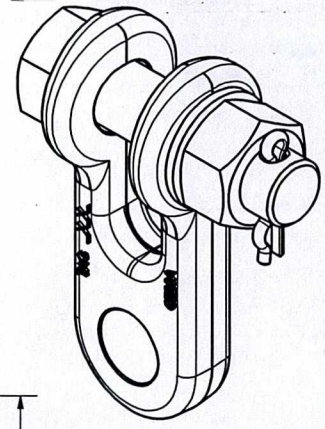

**ISO VIEW**

Project Name Package 03: Supply and transport of insulators and fittings, OPGW cable and accessories for 220kV Thai Binh - Tien Hai - Truc Ninh double circuit transmission line

P.O.Ref.No. -

Purchaser M/s. NPMB

Contractor M/s.

Manufacturer TAG CORPORATION, CHENNAI.

REV	DATE	DESCRIPTION	APP. BY
REVISION HISTORY			

ITEM NAME: **CLEVIS EYE**

DRG.NO: **CE2000** DATE 14.12.2016  
 DRAWN BY P.R.B  
 CKD. BY R.M  
 APP. BY V.T.C  
 SCALE: 1 : 1

ITEM	DESCRIPTION	MATERIAL	ITEM CODE	UTS	QTY (NOS.)
5	SPLIT PIN(SP/001)	S.S (AISI - 304)	B00210001	-	1
4	FLAT WASHER (M22)	GALVANIZED STEEL	B00205006	-	1
3	NUT (M22)	GALVANIZED STEEL (P.C.5.0)	-	-	1
2	BOLT (M22X85)	GALVANIZED STEEL (P.C.5.6)	B00202042	-	1
1	CLEVIS EYE	GALVANIZED STEEL	M00503011	160	1

**BILL OF MATERIAL**

**TAG CORPORATION**  
 CHROME PET, CHENNAI - 600 044  
 EXPORT TAMILNADU, INDIA.

THIS DRAWING IS THE PROPERTY OF "TAG CORPORATION" AND SHOULD NOT BE COPIED OR REPRODUCED WITHOUT PROPER AUTHORIZATION.

ITEM CODE G 0 0 2 0 2 0 3 7

- TECHNICAL DATA**
- HOT DIP GALVANIZED AS PER ISO : 1461.
  - BREAKING STRENGTH - **210 KN.**
  - GENERAL TOLERANCE UNLESS OTHERWISE SPECIFIED IS  $\pm 3\%$ .
  - TOTAL WEIGHT - **9.93 kg.**
  - WEIGHT IS INDICATIVE ONLY.
  - ALL DIMENSIONS ARE IN MM.

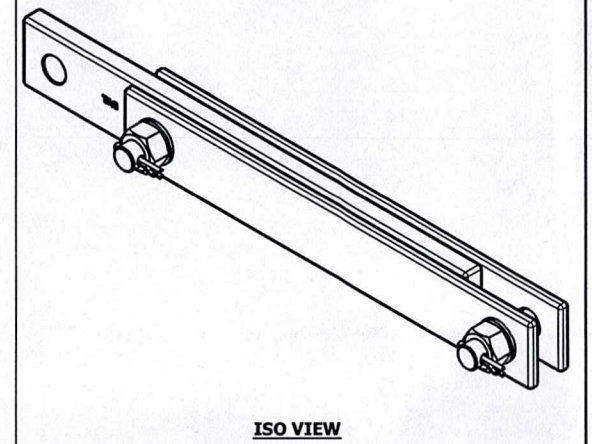
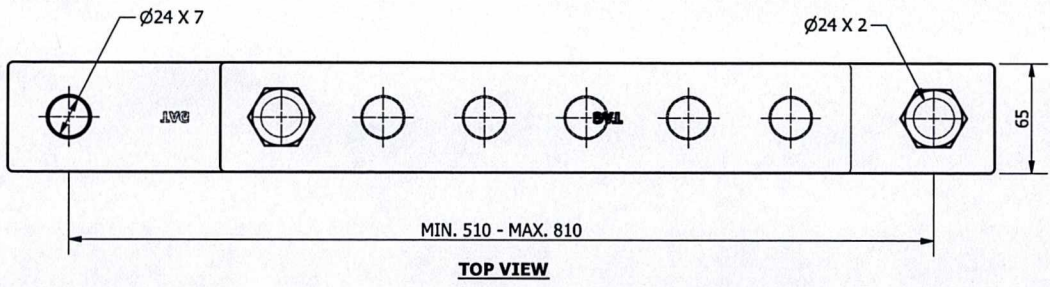
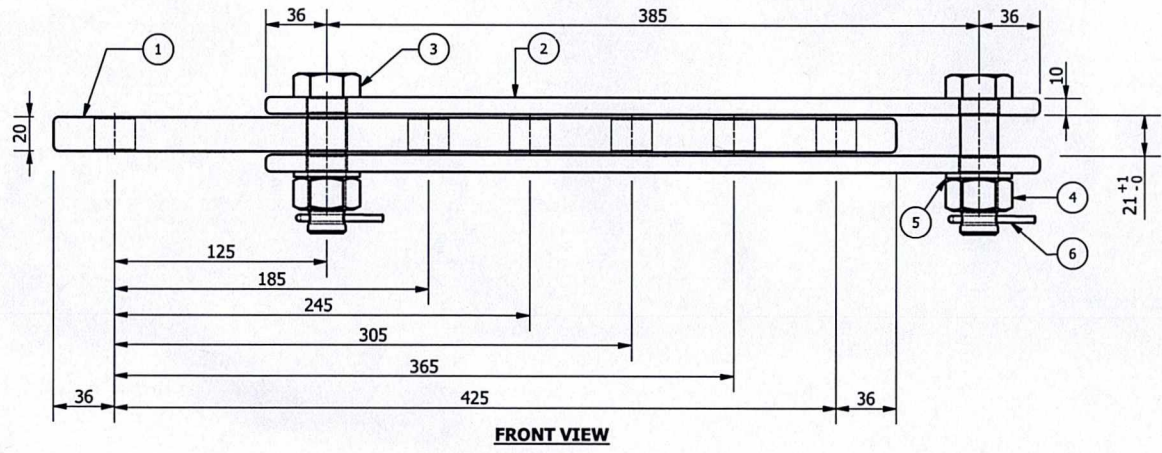

Project Name	Package 03: Supply and transport of insulators and fittings, OPGW cable and accessories for 220kV Thai Binh - Tien Hai - Truc Ninh double circuit transmission line		
P.O.Ref.No.	-		
Purchaser	M/s. NPMB		
Contractor	M/s.		
Manufacturer	TAG CORPORATION, CHENNAI.		
REV	DATE	DESCRIPTION	APP. BY

ITEM NAME:		ADJUSTABLE EXTENSION PLATE	
DRG.NO: AEP4202	DATE	14.12.2016	
	DRAWN BY	P.R.B	
	CKD. BY	R.M	
	APP. BY	V.T.C	
EXPORT	SCALE: 1:3		

ITEM	DESCRIPTION	MATERIAL 2	ITEM CODE	UTS	QTY (NOS.)
6	SPLIT PIN(SP/002)	S.S (AISI - 304)	B00210002	-	2
4	NUT (M22)	GALVANIZED STEEL (P.C.8.0)	-	-	2
5	FLAT WASHER (M22)	GALVANIZED STEEL	B00205006	-	2
3	BOLT (M22X80)	GALVANIZED STEEL (P.C.8.8)	B00203001	-	2
2	ADJUSTABLE EXTENSION PLATE	GALVANIZED STEEL	M00603088	105	2
1	ADJUSTABLE EXTENSION PLATE	GALVANIZED STEEL	M00601067	210	1

**BILL OF MATERIAL**

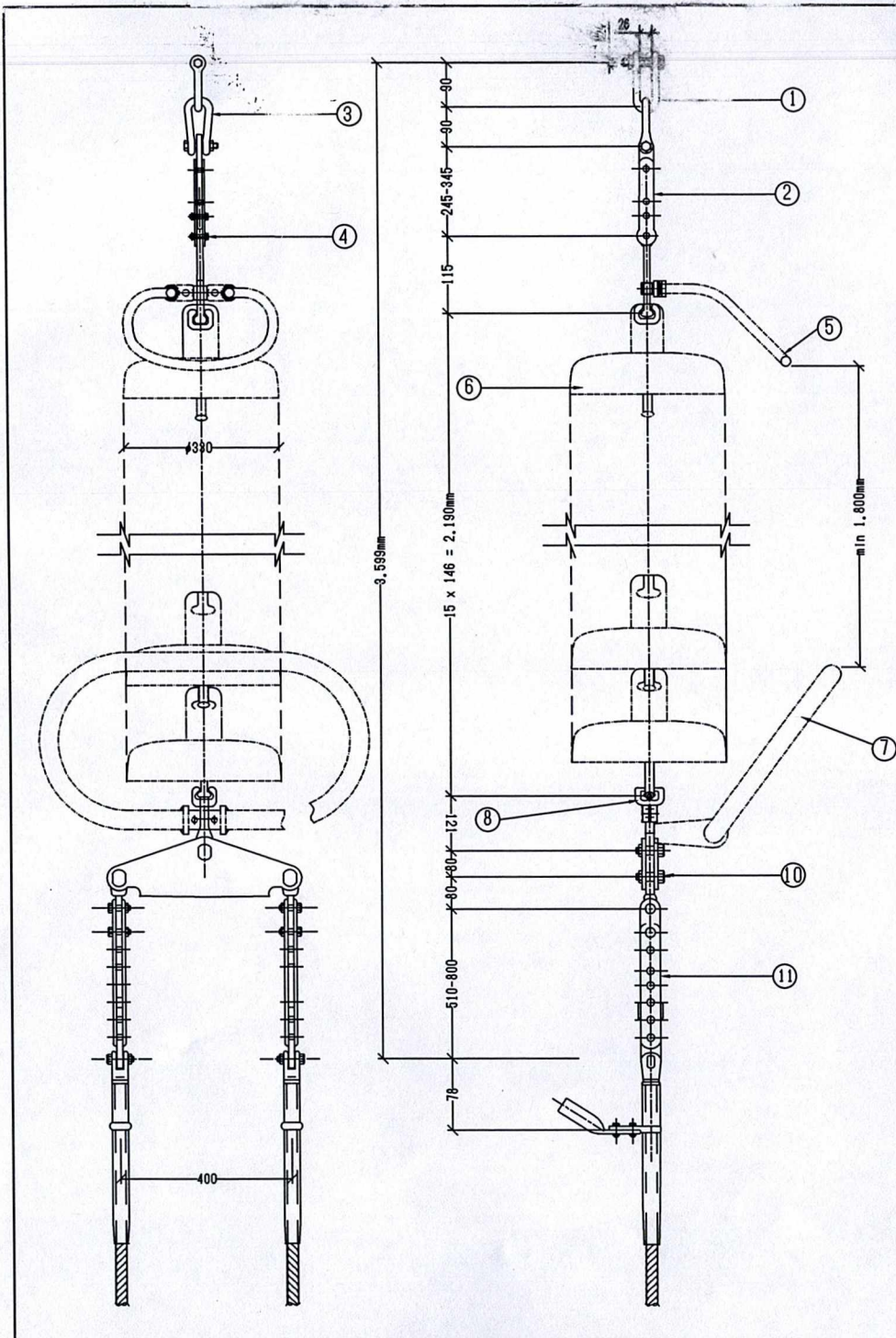

**BẢNG KÊ CẤU KIỆN**

STT	Tên phụ kiện	Tải trọng phá hoại (kN)	Số lượng	Vật liệu chế tạo
1	Ma ní	160	01	Hiện hữu
2	Mắt nối điều chỉnh	160	01	-nt-
3	Mắt nối	160	01	-nt-
4	Vòng treo đầu tròn	160	01	-nt-
5	Arc (Racquet)	-	01	Thép mạ kẽm - Thay mới
6	Cách điện U160BSP	160	15	Gốm/Thuỷ tinh - Thay mới
7	Arc (Racquet)	-	01	Thép mạ kẽm - Thay mới
8	Mắt nối	160	01	Hiện hữu
9	Khánh	160	01	-nt-
10	Mắt nối	160	02	-nt-
11	Mắt nối điều chỉnh	210	02	-nt-
12	Khoá néo	>95% UTS of conductor	02	-nt-

**GHI CHÚ:**

- Tất cả các kích thước tính bằng đơn vị mm
- Tải trọng giới hạn của chuỗi cách điện là 160kN
- Số lượng bát: 15 bát loại U160BSP đang tính toán với dòng rò là 440mm/kV.
- Chuỗi cách điện sử dụng cho dây dẫn 2xACSR 400/51 Mz

Đường rò qui định (mm/kV)	Ký hiệu cách điện	Tổng chiều dài đường rò min (mm)
25	NDD.1-160	6600

**ĐƯỜNG DÂY 220kV MẠCH KÉP  
THÁI BÌNH - TIỀN HẢI - TRỰC NINH**

**CHUỖI NÉO ĐƠN DÂY DẪN ĐIỆN  
NDD.1.160**